

**CLASS I APPLICATIONS  
15 CUBIC FEET**



# Model YZ102

**Type Y or Z  
Purge Unit**

## Installation & Operation Manual

BPS YZ102 IOM-R1.0

9/18



**Model YZ102-CI-L-U  
Less Pressure Switch  
shown w/ Mounting Flange**



**Model YZ102-CI-W or B-V  
With Pressure Switch  
shown w/ Mounting Flange**



**Model YZ102-CI-W or B-H  
With Pressure Switch  
shown w/ Mounting Flange**



**Best Purging Systems**  
Enclosure Purging & Pressurization Solutions

4725 Lawndale • La Marque, Texas 77568

Phone: 1.844.PURGE IT • 1.844.787.4348  
www.purgeit.com • sales@purgeit.com

# Introduction

## Table of Contents

|               |  |                |  |
|---------------|--|----------------|--|
| <b>Page 2</b> | <b>Introduction</b><br>Technical Description<br>Important Notes<br>Important Manual Information Designators  | <b>Page 6</b>  | <b>Mounting &amp; Installation</b><br>Universal, Vertical & Horizontal Mount Purge Unit & Purge Vent Dimensions                                  |
| <b>Page 3</b> | <b>Identifying Your Unit</b><br>Model Number Designations<br><br><b>General Information</b><br>Unit Specifications<br>Material Specifications<br>Protected Enclosure Criteria<br>Major Components List | <b>Page 7</b>  | <b>Mounting Set Up</b><br>Unit Mounting Instructions<br>Unit Tubing Instructions<br>Enclosure Warning Label(s)                                   |
| <b>Page 4</b> | <b>Getting Starting</b><br>Pressurization Unit & Enclosure Connection Requirements<br>Single Enclosure Connections<br>Multiple Enclosure Connections   | <b>Page 8</b>  | <b>Pressurization Unit &amp; Switch Set Up</b><br>Pressurization Unit Set Up<br>Pressure Switch Set Up<br>Typical Pressure Switch Wiring Diagram |
| <b>Page 5</b> | <b>Unit Layout</b><br>Unit Layout & Component Description<br>Typical Pneumatic Flow Diagram  | <b>Page 9</b>  | <b>Pressurization Unit Operation</b><br>Cross Ventilation Diagram  |
|               |  | <b>Page 10</b> | <b>Warranty &amp; Liability Statements</b>   |
|               |  | <b>Page 11</b> | <b>Factory Repair &amp; Service Guide</b>  |
|               |  | <b>Page 12</b> | <b>Reference Information</b>   |
|               |  | <b>Page 13</b> | <b>Maintenance &amp; Service Notes</b>   |
|               |  | <b>Page 14</b> | <b>Unit Identification Information</b>   |

## Technical Description

**Model YZ102** is a Type Y or Z purge unit designed to protect electrical equipment in Class I hazardous locations. Type Z applications reduce the hazardous location rating inside the enclosure from Division 2/ Zone 2 to non hazardous. This allows general purpose equipment to operate in Division 2/ Zone 2 areas. Type Y applications reduce the hazardous location rating inside the enclosure from Division 1/ Zone 1 to Division 2/ Zone 2. This allows Division 2/ Zone 2 equipment to operate in Division 1/ Zone 1 areas.

**Model PV-2** spark arresting Purge Vent **MUST** be installed on the protected enclosure.

This unit is designed to meet or exceed NEC - NFPA 70, NFPA 496, EN 50016 and IEC 60079-02 requirements.

## IMPORTANT NOTE

**Operating this unit without a Model PV-2 Purge Vent may cause harm, death or dismemberment to personnel and can cause damage to instrumentation.**

**This unit is NOT intended for dilution applications. Please consult factory for more information.**

A copy of this manual must be read and retained by the operator of this unit. User's agent's are responsible for transferring this manual to the user prior to installation and start up.

This unit must be installed and operated per this manual. The Authority Having Jurisdiction should be advised before installation of this unit. This manual DOES NOT supersede any national, local or plant codes.

**All specifications are subject to change without notice.**

## Important Manual Information Designators

To assist you through the installation and operation of your enclosure pressurization unit, Best Purging Systems has provided the following information boxes throughout this manual. This information is intended to clarify certain differences between the model styles and configurations of this unit and to warn the user and installer of potential dangers due to improper installation or operation.

### HELPFUL HINT

### IMPORTANT NOTE

### WARNING

# Identifying Your Unit

## Model Number Designations

|   |                                 |
|---|---------------------------------|
| <b>Model # YZ-102-CI-L-U-<math>\pi</math></b> |                                 |
| <b>Div./Zone Reduction</b>                    | <b>Voltage*</b>                 |
| Y- Div.1/Zone1 to Div. 2/Zone 2               | 120 VAC                         |
| Z- Div.2/Zone2 to Non-Hazardous               | 24 VDC                          |
| <b>Unit Series</b>                            | OR                              |
| 102- 1/4" Purge Unit                          | <b>Optimal Configuration***</b> |
| <b>Area Classification</b>                    | PM- Panel Mount                 |
| CI- Class I Areas                             | <b>Mounting Options</b>         |
| <b>Pressure Switch Option</b>                 | U- Universal Mounting**         |
| L- Provided Less Switch                       | V- Vertical Mounting            |
| W- Provided With CI, Gr. C&D EXP Switch       | H- Horizontal Mounting          |
| B- Provided With CI, Gr. B EXP Switch         |                                 |

\* For pressure switch option "B" only

\*\* Not Available with pressure switch options

\*\*\* Panel Mount designed to mount through the wall of protected enclosure. U mounting only.

This enclosure pressurization unit is offered in various styles. For proper installation and operation, examine the Unit Model Number Nameplate to identify the Unit Style, Area Classification and Type, as noted below.

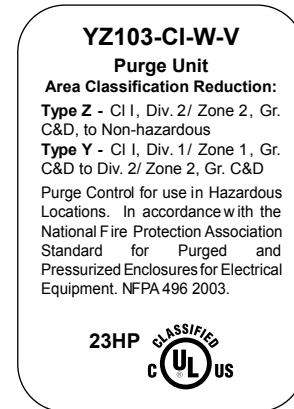

## General Information

### Unit Specifications

|                           |                                 |
|---------------------------|---------------------------------|
| Purge Time:               | 4 Volumes @ 1 minute per 1.0 cf |
|                           | 5 Volumes @ 1 minute per 0.8 cf |
| Protective Gas Supply:    | Air or Inert Gas                |
| Gas Supply Pressure:      | 80 - 125 psi max.               |
| Unit Supply Connection:   | 1/4" tube fitting               |
| Enclosure Supply:         | 1/4" tube fitting               |
| Enclosure Reference:      | 1/4" tube fitting               |
| Safe Enclosure Pressure:  | 0.25" w.c. / 6.22 Kb            |
| Safe Press. Flow Rate:    | * 0.1 - 3.5 scfh per cf         |
| Purge Enclosure Pressure: | * 5" - 8" w.c.                  |
| Purge Press. Flow Rate:   | 4 scfm @ 60 psi.                |

\* Enclosure Integrity determines actual Pressure & Flow

### Material Specifications

|                          |                             |
|--------------------------|-----------------------------|
| Unit Mounting Plate:     | 316 Stainless Steel Brushed |
| Regulator body:          | Enamel Finished Zinc        |
| Filter & Handle:         | Polycarbonate               |
| Enclosure Press. Gauge:  | Enameled Aluminum           |
| Injection Press. Gauge:  | Polycarbonate/Brass         |
| Tubing:                  | 316 Stainless Steel         |
| Tube Fittings:           | 316 Stainless Steel         |
| Valves:                  | 316 Stainless Steel         |
| Valve Handles:           | Polycarbonate               |
| Start up Labels:         | Silkscreened Lexan          |
| Enclosure Warning Label: | Stainless Steel             |

### Protected Enclosure Criteria

The consumption of protective gas is directly related to the integrity of the protected enclosure plus the type of purge requirements, i.e. dilution and ventilation. The following enclosure recommendations are provided to help minimize protective gas consumption and increase purge unit efficiency.

1. The enclosure should be fabricated to meet NEMA 4 or 12 / IP66 requirements.
2. Non metallic enclosures should meet ANSI/UL 94 V-O or 94 5V.
3. Enclosure windows should be impact resistant and sized as small as possible.
4. Enclosure surface temperatures must not exceed 80% of the area's auto-ignition temperature.
5. Avoid obstructions and barriers which could impede protective gas flow through the protected enclosure.

### Major Components List

|                               |       |
|-------------------------------|-------|
| Filter Regulator:             |       |
| Enclosure Pressure Valve:     |       |
| Purge Valve:                  |       |
| Purge Press. Indicator:       |       |
| Enclosure Press. Indicator:   |       |
| Optional Pressure Loss Alarm: |       |
| Enclosure Warning Label:      | EWL-1 |

## WARNING

All electrical connections of the protected enclosure and purge unit must be performed by trained and knowledgeable personnel. In addition, all connections must be installed in accordance with the National Electrical Code (NEC) NFPA 70 and all relevant international, nation and local codes. The Authority Having Jurisdiction must approve all electrical installations. Failure to follow electrical warnings can cause harm, death or dismemberment to personnel and can cause damage to instrumentation.

# Getting Started

## Purge Unit & Enclosure Connection Requirements

1. No valves shall be installed between the Pressurization/Purge Unit and the Protected Enclosure.
2. The Pressurization/Purge Unit should be located at eye level.
3. The Pressurization/Purge Unit should be installed adjacent to the protected enclosure.
4. Enclosure Supply and Purge Vent should be installed at extreme opposite corners, to ensure adequate purge flow through the Protected Enclosure.
5. Multiple Protected Enclosures must be purged in series and should be connected from the smallest to the largest enclosure.
6. Enclosure Supply connections between multiple enclosures must be at least the diameter of the Purge vent exhaust (3/4").

## Single Enclosure Connections

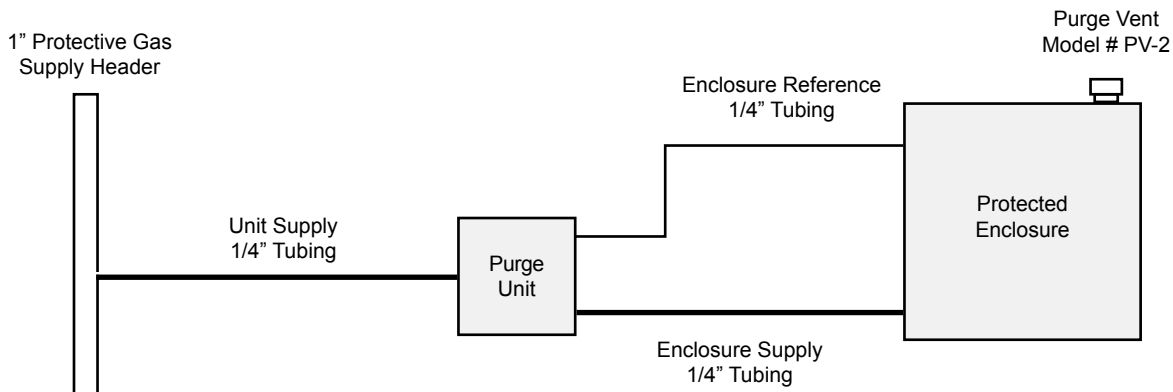

## Multiple Enclosure Connections

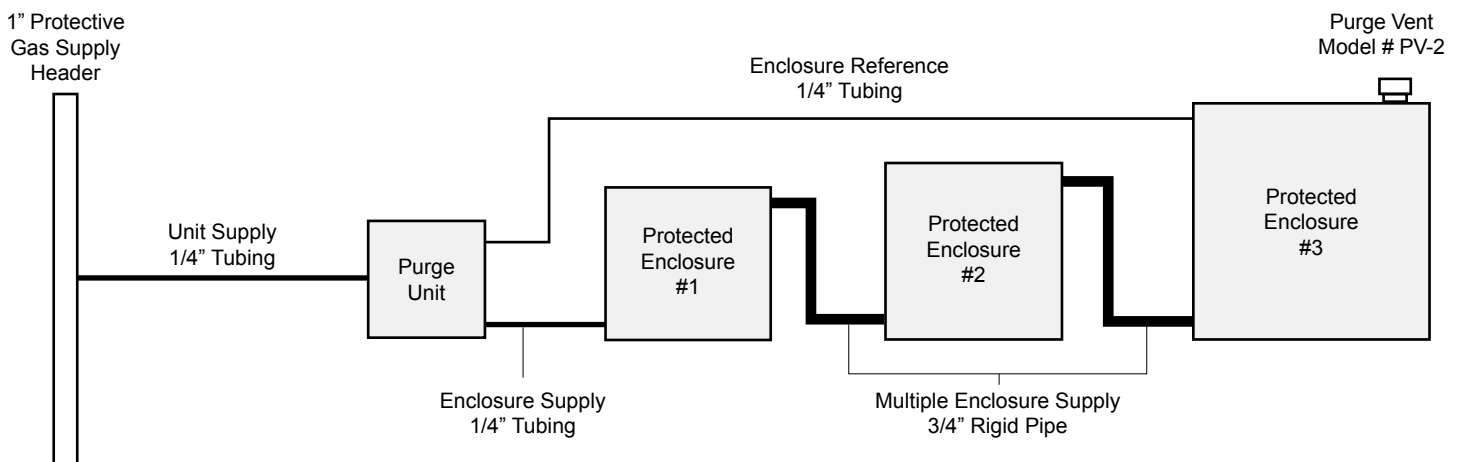

# Unit Layout

## Unit Layout & Component Description

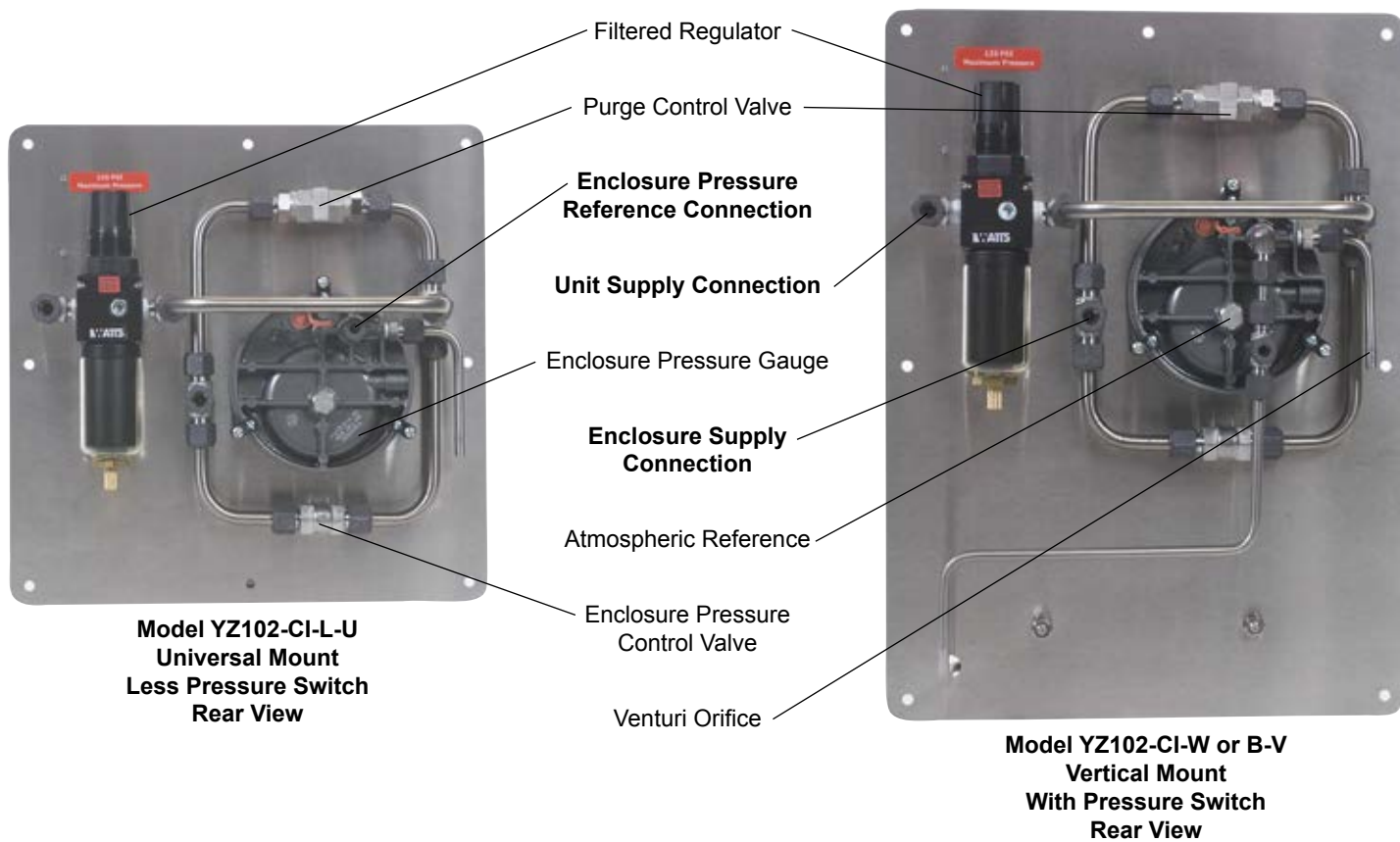

## Typical Pneumatic Flow Diagram

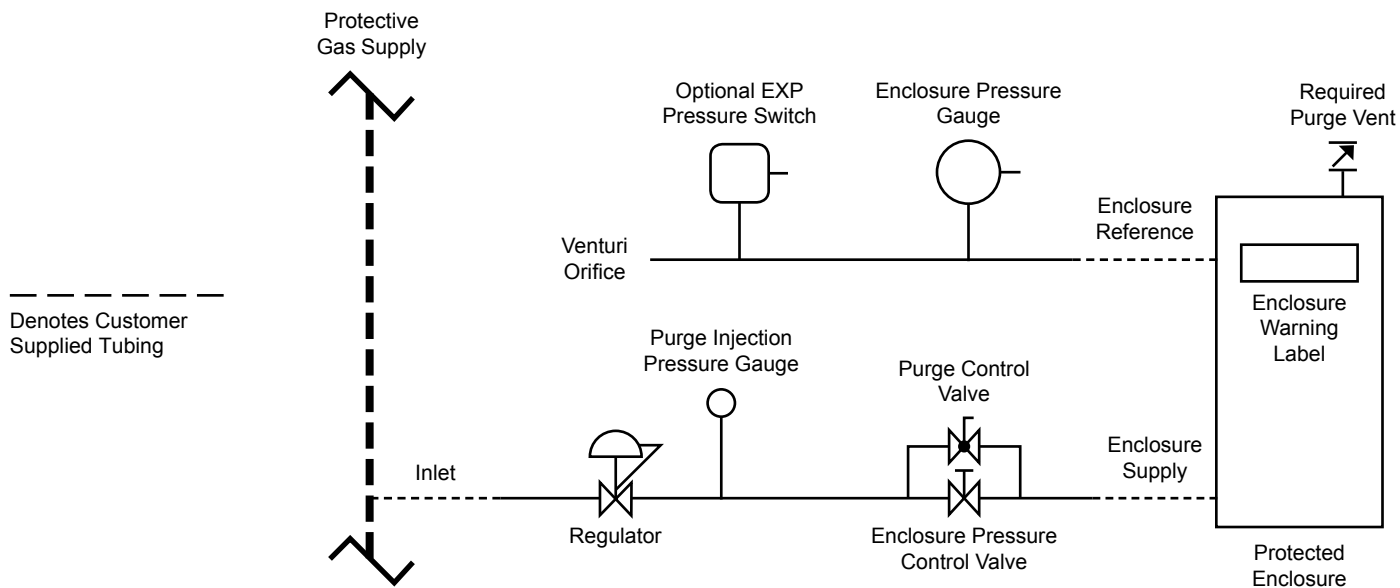

# Mounting & Installation

## Universal Vertical & Horizontal, Mount Purge Unit & Purge Vent Dimensions

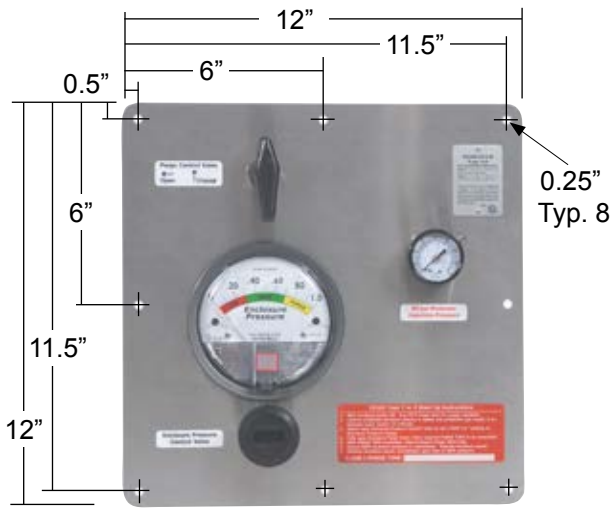

**Model YZ102-CI-L-U  
Front View**

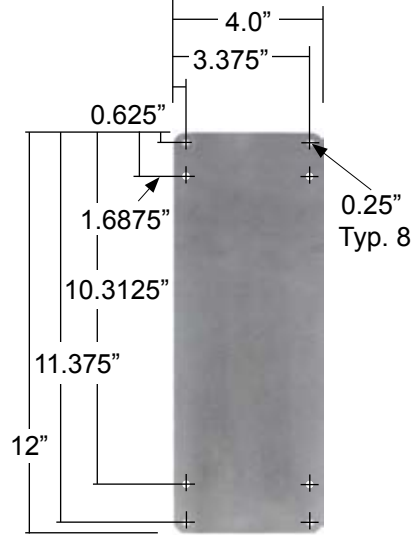

**12" Universal  
Mounting Flange**

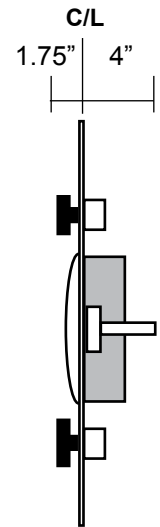

**YZ102-CI-L-U  
Side View**

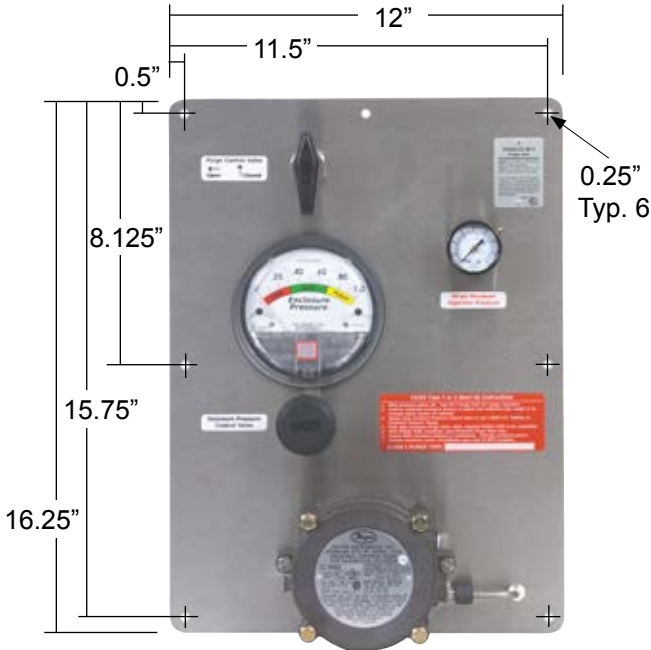

**Model YZ102-CI-W or B-V  
Front View**

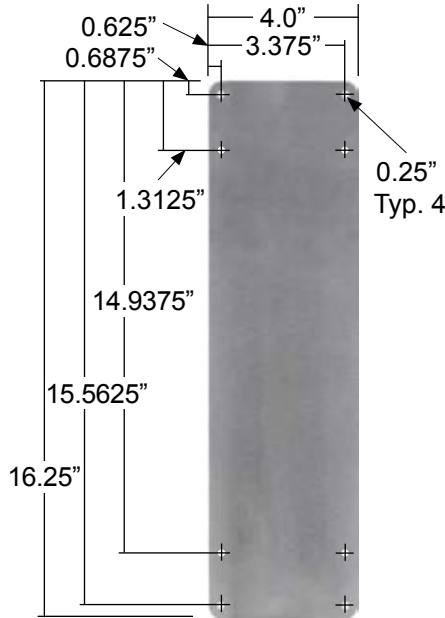

**Model YZ102-CI-W or B  
Mounting Flange**

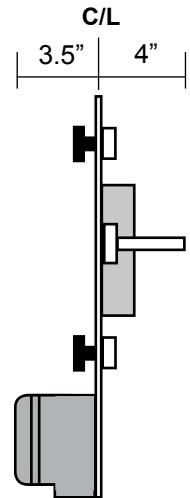

**Model YZ102-CI-W or B  
Side View**

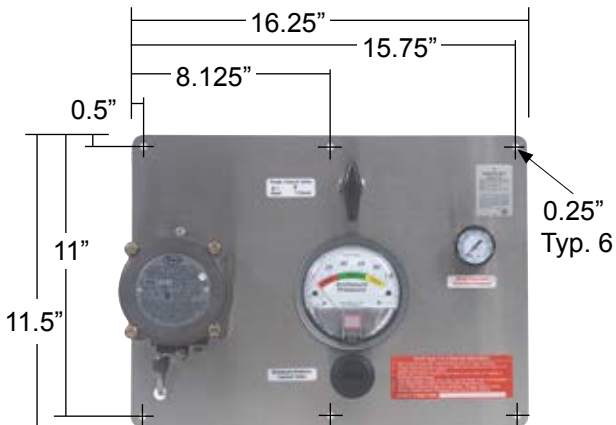

**Model YZ102-CI-W or B-H  
Front View**



**Model PV-2-T  
Top Mount Purge Vent**

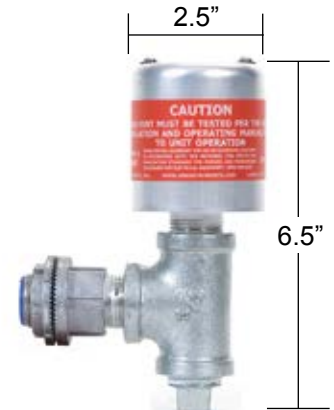

**Model PV-2-S  
Side Mount Purge Vent**

# Mounting Set Up

## Unit Mounting Instructions

- Carefully read "Protected Enclosure Criteria" on page 3 and "Enclosure Connection Requirements" on page 4 before proceeding.
- Determine the Mounting configuration for the purge unit. See "Typical Mounting Configurations."
- Firmly secure the unit mounting flange, if utilized, to the unit face plate using the hardware provided.
- Drill and ream four mounting holes in the protected enclosure. (see page 6 for unit mounting flange dimensions and unit layout)
- Based on "Enclosure Connection Requirements" on page 4, drill and ream a 29/64" hole in protected enclosure, install 1/4" Enclosure Supply Bulkhead fitting. NOTE: Protected Enclosure Supply should be installed at extreme opposite corner from part # PV-2 Purge Vent and 8" from the Enclosure Reference Connection.
- Next, drill and ream a 29/64" hole in protected enclosure, install 1/4" Enclosure Reference Bulkhead fitting. NOTE: Protected Enclosure Reference should be installed at least 8" from the Enclosure Supply Connection.
- Install PV-2 Purge Vent at extreme opposite corner from the Enclosure Supply Connection. **(WARNING: The PV-2 Purge Vent is gravity operated and MUST be mounted in a true vertical position.)**
- Install the PV-2 Purge Vent Mounting Hub through a 1-1/4" hole on the Protected Enclosure.
- Secure the Purge Vent from inside the Protected Enclosure using the Purge Vent Mounting Nut.
- Secure Purge Unit Mounting Flange to protected enclosure using hardware provided.

## Unit Tubing Instructions

- Carefully read "Protected Enclosure Criteria" on page 3 and "Enclosure Connection Requirements" on page 4 before proceeding.
- The following instructions are for Units mounted external to the Protected Enclosure. Consult factory for units which are mounted inside or through the face of the Protected Enclosure.
- Connect 1" Protective Gas Supply Header to Unit Supply Connection using 1/4" .035 welded or seamless wall stainless steel, fully reamed tubing. Protective Gas Supply tubing should not exceed 15 feet length and 5 bends.
- Connect Unit Enclosure Supply Connection to the Enclosure Supply bulkhead fitting using 1/4" .035 welded or seamless wall stainless steel, fully reamed tubing. Enclosure Supply tubing should not exceed 5 feet in length and 5 bends.
- MULTIPLE ENCLOSURE CONNECTIONS ONLY.** Connect Multiple Enclosure Protective Gas Supply Piping (3/4" rigid pipe, fully reamed) from Protected Enclosure #1 to Protected Enclosure #2. Repeat procedure for connection between Protected Enclosure #2 and #3. Protective Gas Supply piping should not exceed 10 feet length and 5 bends between each enclosure.
- Connect Unit Enclosure Reference Connection to the Enclosure Reference bulkhead fitting using 1/4" .035 welded or seamless wall stainless steel, fully reamed tubing. Enclosure Reference tubing should not exceed 20 feet length and 5 bends.

## Typical Mounting Configurations



Left Mount



Top Mount



Bottom Mount



Frame/Panel Mount



Right Mount

## Enclosure Warning Label(s)

Enclosure Warning Label (EWL) **MUST** be permanently affixed on or near all protected enclosure doors, entries and openings.

### WARNING - PRESSURIZED ENCLOSURE

ENCLOSURE SHALL NOT BE OPENED UNLESS AREA IS KNOWN TO BE FREE OF FLAMMABLE MATERIALS OR UNLESS ALL DEVICES HAVE BEEN DE-ENERGIZED. POWER SHALL NOT BE RESTORED AFTER ENCLOSURE HAS BEEN OPENED UNTIL COMBUSTIBLE DUSTS HAVE BEEN REMOVED AND ENCLOSURE HAS BEEN PURGED AND PRESSURIZED IN ACCORDANCE WITH THE UNIT START UP INSTRUCTIONS.

AREA CLASSIFICATION: \_\_\_\_\_ PRESSURIZATION TYPE: \_\_\_\_\_ TEMPERATURE CODE: \_\_\_\_\_  
 BEST PURGING SYSTEMS CORPORATION WWW.PURGEIT.COM LA MARQUE, TEXAS USA

### WARNING NOTICE

#### THIS ENCLOSURE CONTAINS HOT COMPONENTS

ENCLOSURE SHALL NOT BE OPENED UNLESS AREA IS KNOWN TO BE FREE OF FLAMMABLE MATERIALS OR UNLESS ALL DEVICES HAVE BEEN DE-ENERGIZED FOR THE TIME SPECIFIED BELOW.

MINIMUM COOLONG TIME: \_\_\_\_\_

BEST PURGING SYSTEMS CORPORATION WWW.PURGEIT.COM LA MARQUE, TEXAS USA

# Purge Unit Set Up

## Pressurization Unit Set Up

1. Ensure Protected Enclosure Power is OFF, Enclosure Pressure Control Valve and Purge Control Valve are closed and Protective Gas Supply is ON.
  2. Test the Purge Vent, Model PV-2, for proper operation. Using the eraser end of a pencil or similar object, insert test object from inside the enclosure to confirm vent relief ball is operating properly. Note: For side mounted, Model PV-2-S, remove plug from bottom of tee fitting to test vent relief ball operation.
  3. Close and Seal Protected Enclosure.
  4. Slowly turn Enclosure Pressure Control Valve CCW until a "Safe" 0.25" w.c. reading is shown on the Enclosure Pressure Indicator. Note: Should Enclosure Pressure Control Valve require more than a quarter turn to obtain a "safe" enclosure pressure, carefully check all enclosure connections and doors for leakage. Seal as needed.
  5. Ensure a Minimum 60 psi reading on the Purge Injection Pressure Gauge, adjust regulator if required.
  6. Open the Purge Control Valve fully. The Enclosure Pressure Gauge will go off scale to the high side, this normal.
  7. During Purge cycle, confirm minimum 60 psi reading on Purge Injection Pressure Gauge, adjust regulator if required.
  8. Close Purge Control Valve fully. The Enclosure Pressure Indicator should return to a "Safe" 0.25" w.c. reading.
  9. Calculate total protected enclosure volume (when empty). Determine Purge Time required (5 minutes minimum).
- | Required Exchange | Time/Enclosure Volume |
|-------------------|-----------------------|
| 4 Volumes         | 1 minute per 1.0 cf   |
| 5 Volumes         | 1 minute per 0.8 cf   |
10. Mark purge time on Unit start up instruction name tag using a permanent marker.
  11. Set up is complete. Remove any test equipment and proceed to Optional Enclosure Pressure Switch Set up if required.

## Pressure Switch Set Up

1. The following directions are for purge models with the suffix -W or -B which are supplied with a flame proof differential pressure switch (DPS).

### IMPORTANT NOTE

The differential pressure switch is intended solely for loss of safe pressure alarm and should not be used to control power to the protected enclosure.

2. Connect alarm system wiring to the DPS via rigid conduit and seal or other approved wiring method for the classified location.
3. The DPS provides a Form C Dry NO, NC and C contact  
Note: -B switches require 120V AC or 24V DC power to operate.
4. The alarm system should be connected in a fail safe configuration.

### Typical Pressure Switch Wiring Diagram

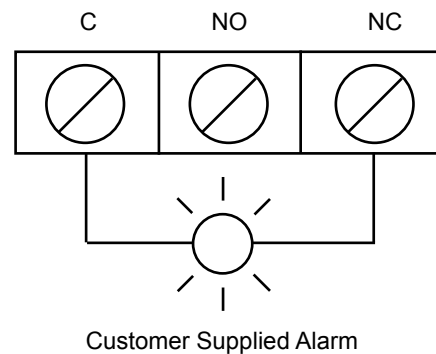

## Cross Ventilation Diagram

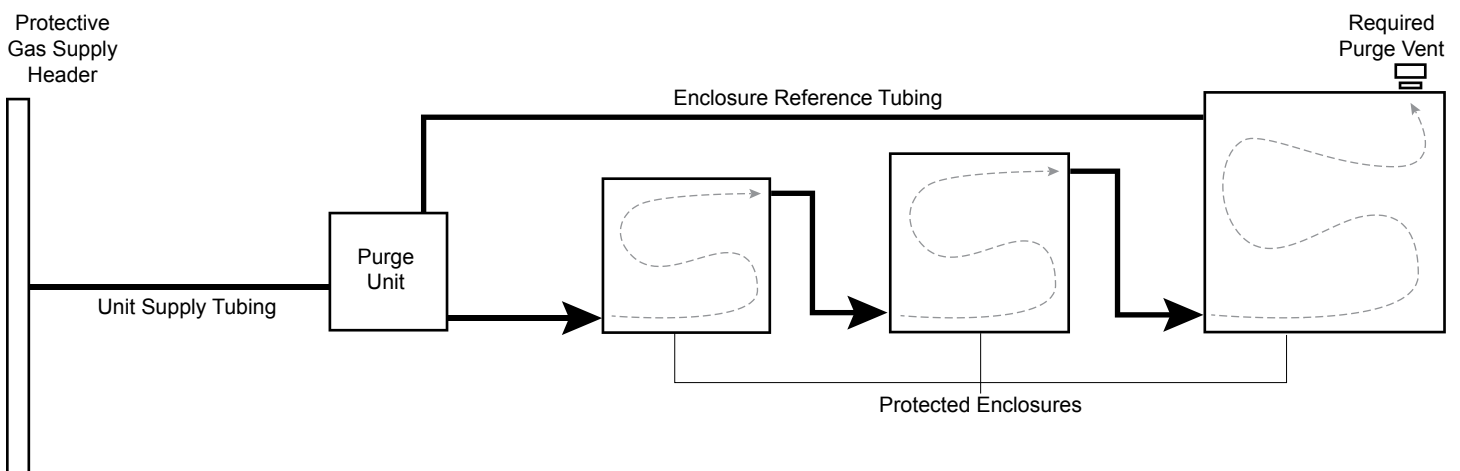



# Purge Unit Operation

1. Ensure Protected Enclosure Power is OFF, Enclosure Pressure Control Valve and Purge Control Valve are closed, Protective Gas Supply is ON and alarm system is activated (if utilized).
2. Test the Purge Vent, Model PV-2, for proper operation. Using the eraser end of a pencil or similar object, insert test object from inside the enclosure to confirm vent relief ball is operating properly. Note: For side mounted, Model PV-2-S, remove plug from bottom of tee fitting to test vent relief ball operation.
3. Close and Seal Protected Enclosure.
4. Slowly turn the Enclosure Pressure Control Valve CCW until a "Safe" 0.25" reading is shown on the Enclosure Pressure Indicator.
5. Open the Purge Control Valve fully. The Enclosure Pressure Indicator will go off scale to the high side, this is normal.
6. Confirm a Min. 60 psi on Purge Injection Pressure Gauge.
7. Allow unit to purge protected enclosure for the required time marked on the Unit Start Up Instructions (5 minutes minimum).
8. Upon completion of the required purge time, close the Purge Control Valve fully. The Enclosure Pressure Indicator will return to a "Safe" 0.25" w.c. reading.
9. Confirm protected enclosure "Safe" pressure is stable. Energize protected enclosure equipment.
10. Loss of "safe" pressure requires immediate attention. Protected enclosure power should be deenergized if "Safe" pressure cannot be restored within a reasonable amount of time.

| Required Exchange | Time/Enclosure Volume |
|-------------------|-----------------------|
| 4 Volumes         | 1 minute per 1.0 cf   |
| 5 Volumes         | 1 minute per 0.8 cf   |

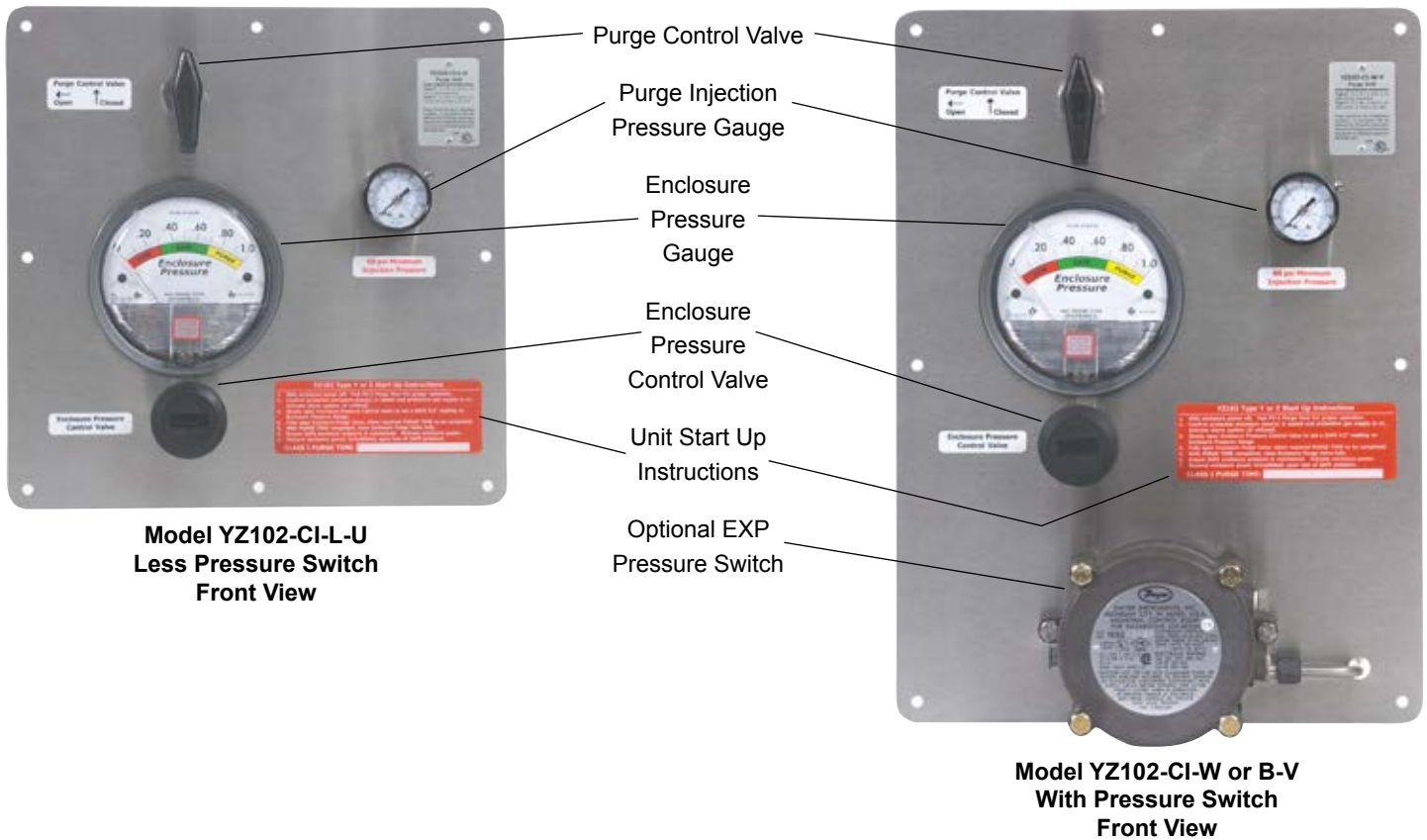

# Warranty & Liability Statements

## Limited Warranty Terms

**ADVISEMENTS:** This Warranty Statement is an excerpt for reference only, and is therefore superseded by any variance of Warranty Terms and Conditions supplied with the Quotation or Sales Order Documents provided for this particular Product. All parts and services provided for this Product must be made with Best Purging Systems Corporation (hereafter referred to as BEST) furnished or authorized service parts and by BEST Technicians or by a BEST authorized service provider. Reference Quotation and Sales Order Documents for complete Terms and Conditions, including clauses regarding warranty extensions, safety certifications, trade certifications and insurance, special safety equipment and tools, required working conditions, warranty registration requirements, eligibility, exclusions and legal terms.

**WARRANTY CONDITIONS:** Subject to all terms and conditions herein, BEST extends a limited warranty against manufacturing defects and workmanship for all Product that is installed and operated by the Purchaser and/or Client in complete accordance with all instructions in the BEST Installation, Operation and Maintenance Manual in the United States, Canada and Mexico.

**WARRANTY TERM:** The Base Limited Warranty period for Product is effective for Twelve (12 Months) from date of BEST Factory shipment. Upon proper registration of the Product by the Purchaser or Client within no more than Ninety (90) Days after BEST Factory shipment, a Registered Limited Warranty shall become effective and extend the warranty period to Twenty-Four (24) Months after date of shipment. Regardless of registration, the Commencement Date for either warranty period shall be the date of BEST Factory shipment, or under prior special written agreement at time of Product purchase, no greater than Ninety (90) Days after the BEST Factory shipment date.

**WARRANTY EXTENSIONS:** An extended warranty shall extend the effective warranty based on the terms and conditions as negotiated at time of purchase. The purchase of site start-up services or site acceptance testing from BEST and/or their authorized service provider under contract to BEST shall alter the warranty Commencement Date of the Basic, Registered or Extended Warranty period to begin on the day after Client Acceptance of site start-up services or site acceptance testing.

**TERM LIMITATION:** The installation of Product replacement parts and/or the provision of any field service or troubleshooting services under this limited warranty shall not extend the effective warranty period. The warranty period for any supplemental installation of Product replacement parts and/or the provision of any field service or troubleshooting services under this limited warranty shall therefore be applicable only during the warranty period remaining under the effective Product Warranty.

**WARRANTY COVERAGE:** The Base Limited Warranty covers all necessary parts and labor during the first Twelve (12) Months or up to Twenty-Four (24) Months after date of shipment if product is registered in accordance with this warranty. Under either warranty term, the warranty shall be effective to resolve any validated defect in parts and/or workmanship and is provided exclusively for the Purchaser during integration and the Client upon delivery to the site of installation and use. Warranty is transferable from Purchaser to Client and shall be in full effect and force during any hold over, commissioning or factory acceptance testing of Product regardless of whether Product is operational or at installation site, except according to terms stated below under Registration Requirements.

**WARRANTY REPAIR SERVICES:** BEST may request proof of Product purchase and/or installation in order to provide Product parts and service under this limited warranty. As BEST's only responsibility and Purchaser and Client's only remedy under this limited warranty, BEST will furnish all necessary labor and/or replacement parts in accordance with Warranty Coverage Terms above, whether provided by BEST or an authorized service provider acting on BEST's behalf, without charge for the labor and/or parts, to repair any Product that fails due to a manufacturing defect under normal use and maintenance. If a replacement part is not available at time of warranty service, BEST may, at its option and sole discretion, provide a suitable replacement product. If Client selects unit repair at the BEST factory, the client shall be responsible for freight to BEST, and BEST shall be responsible for cost of standard non-expedited freight back to client, whereas client shall pay the difference for expedited freight if requested.

**NON-WARRANTY SERVICES:** All non-warranted parts provided and/or non-warranted services incurred during a warranty serviced event at the request of the Purchaser or Client shall be provided at Purchaser or Client's sole cost and expense. BEST reserves the right to require a Purchase Order from the Purchaser or Client prior to accommodating any non-warranty services, and will require binding estimates for services from all BEST certified contractors where and when possible or required.

## Limitations of Liability

**WHEREBY** Best Purging Systems Corporation, hereafter referred to as "Manufacturer," is the sole manufacturer of this Product, Manufacturer herein states a portion of the limitations of liability incurred due to any sale or use of the Product.

Manufacturer accepts no liability for any affects or damages incurred by the installation or operation of the Product which is used on any enclosures, cases, containers or combinations thereof which are not constructed in complete accordance with the National Electric Code and all applicable sections of NFPA 496, or which are not specified as acceptable for use within the constraints of design requirements and information that may be contained within this Installation, Operation & Maintenance Manual.

Manufacturer and/or its Agents, Representatives, or Sub-Contractors accept no liability for PERSONAL INJURY, DISMEMBERMENT OR DEATH, or for any affects or damages incurred to any device, component, enclosure, equipment or area caused by use of Product, unless Product is installed, operated and maintained in complete accordance with this Manual and all applicable National Electric Code and NFPA 496 requirements and OSHA regulations.

These Limitations of Liability supersede any and all claims of liability responsibilities claimed by the User and/or its Agents or Subcontractors against Manufacturer and/or its Agents, Representatives, or Sub-Contractors regardless of their Terms of Purchase, surrendered hereto, and shall survive from the date of sale to the date of discontinued use of the Product. Questions concerning stated and unstated limitations to liability may be referred to the Corporate Management Group of the Manufacturer at 4725 Lawndale, La Marque, Texas 77568, USA.

# Factory Repair & Service Guide

## TERMS & CONDITIONS

If all reasonable efforts to resolve an apparent performance issue with a Best Purging Systems Model YZ102 Pressurization Unit do not resolve the issue, a Return Material Authorization (RMA) number may be secured to return the Unit to Best Purging Systems whether the return is for warranty or non-warranty repair, shipping damage, or any other reason.

Please note that shipping damage must be claimed promptly with the carrier and is the responsibility of the recipient.

To procure an RMA number, please contact Best Purging Systems Customer Service at 1-844-PURGE IT (787-4348).

A Best Purging Systems Customer Service Associate will then work with you to resolve any problems with the Unit if at all possible, and also assist you to determine if the Unit is or is not under warranty.

If satisfactory resolution of your problem with the Unit cannot be achieved, an RMA number will be provided under the following terms and conditions:

## Required Information

- Purchase order number and date (may be determined by Best Purging Systems when Serial Number is provided)
- Unit Model Number (available from Model ID Nameplate on Unit)
- Unit Serial Number (available from Model ID Nameplate on Unit)
- Reason for return (our service associate will help you to determine best statement)
- Customer name and contact phone, fax number, address and e-mail address
- Shipping method (name of courier and anticipated arrival date at Best Purging Systems)

## Unit Return Instructions

- Pack Unit in a suitable packing for shipment.
- Utilize original packaging materials if available.
- If original packaging materials are not available, please pack the Unit carefully using available materials
- Improper packaging may void warranty
- Clearly mark the RMA number on the box.
- Customer will pay all freight charges.
- Collect shipments will be refused
- Shipments without RMA number will be refused.

## SERVICE FOR UNITS THAT ARE NO LONGER UNDER WARRANTY PROTECTION

If your Best Purging Systems Model YZ102 Pressurization Units is not covered by warranty and requires repair, please call Best Purging Systems Customer Service at 1-844-PURGE IT (787-4348) for an RMA number.

A Best Purging Systems Customer Service Associate will assist you to determine what repairs or parts are needed and if possible provide an estimate of the cost.

Please note that shipments arriving without an RMA number may be refused and returned at Shipper's Expense.

After the Unit is received and diagnosed, you will receive a detailed estimate for all service and parts required.

The repair and test process may uncover other issues for which you will be informed and given quotes for the work needed.

A written Purchase Order will then be required to verify your authorization to proceed with Unit repair.

# Reference Information

## Reference Publications

These publications will help in the installation of the Enclosure Pressurization Unit. They can be found at your local library or purchased directly from the publisher. NOTE: The publication editions shown below are the most current at time of print. The most current edition of any publication listed below supersedes any printed edition date shown.

National Electrical Code (NEC) -ANSI/NFPA 70  
2017 edition

Standard for Purged And Pressurized  
Enclosures for Electrical Equipment -ANSI/NFPA 496  
2017 edition

Recommended Practice for the Classification of Flammable  
Liquids, Gasses or Vapors and of Hazardous (Classified)  
Locations for Electrical Installations in Chemical Process  
Areas.

NFPA 497  
2017 edition

## Professional Organizations

### **ANSI: American National Standards Institute**

11 West Street, 13th floor  
New York, NY 10036  
(Tel) 212-642-4900 (Fax) 212-302-1286

### **NFPA: National Fire Protection Association**

Batterymarch Park  
P.O. Box 9101  
Quincy, MA 02269-9901  
(Tel) 800-344-3555 (Fax) 617-984-7057



# Unit Identification Information

## Unit Identification & Application

Date of Installation: \_\_\_\_\_

Unit Serial Number: \_\_\_\_\_

Model Number: \_\_\_\_\_

Customer P.O. Number: \_\_\_\_\_

Customer Project Number: \_\_\_\_\_

Service Identification: \_\_\_\_\_

Location: \_\_\_\_\_

Application: \_\_\_\_\_

INSTALLATION NOTES : \_\_\_\_\_

\_\_\_\_\_  
\_\_\_\_\_  
\_\_\_\_\_  
\_\_\_\_\_  
\_\_\_\_\_  
\_\_\_\_\_  
\_\_\_\_\_  
\_\_\_\_\_  
\_\_\_\_\_  
\_\_\_\_\_  
\_\_\_\_\_  
\_\_\_\_\_

